

PRODUCT SHEET
MERIDIAN 6042
 60" X 42" X 21"



THERMOMASSEUR® BATH	\$
THERMASENS® BATH	\$
TUB no therapy	\$

THERMOMASSEUR (TMU)	
Jets	41
1 heated backrest	included
MiaPlus® Control	included
Geysair®	included
AromaCloud®	\$
Chromatherapy - 2 LED	\$

THERMASENS (TMSU)		TUB no therapy
AromaCloud®	included	\$
Chromatherapy - 2 LED	included	\$
WarmTouchShell®	included	\$
DOT control	included	included with therapy

FEATURES			
Installation	Drop-in, Alcove (3 walls) or Undermount*		
No. of bathers	↓	Imp. gallons	52
US gallons	62		

OPTIONAL UPCHARGE APPLICABLE

COLOR		
Standard		
White	Biscuit	
Optional		
Black	Sandbar	Gray

CONTROL (TMU ONLY)

MiaMulti®	\$
-----------	----

SKIRT	MULTIFIT	SJ-1
Skirt	\$	\$
Optional color	\$	\$

WASTE & OVERFLOW 16" X 35"

Chrome	\$
White, Biscuit	\$
Brass	\$
Brushed nickel, Polished nickel & Oil-rubbed bronze	\$

TILE FLANGE (specify right or left)

Ordered with bath, uninstalled	\$
Factory-installed	\$

* THE AROMACLOUD IS NOT AVAILABLE WITH UNDERMOUNT INSTALLATION.

1 800 463.2187 info@bainultra.com From 8 a.m. to 8 p.m. Monday to Thursday (EST)
 From 8 a.m. to 5 p.m. on Friday (EST)

MERIDIAN 6042 60" X 42" X 21"

ACCESSORIES (OPTIONAL)

CUTTING TEMPLATE

90000006

OTHERS

- Optional tile flange (specify right or left).

TOTAL PRICE

\$

ALCOVE/DROP-IN/UNDERMOUNT INSTALLATION

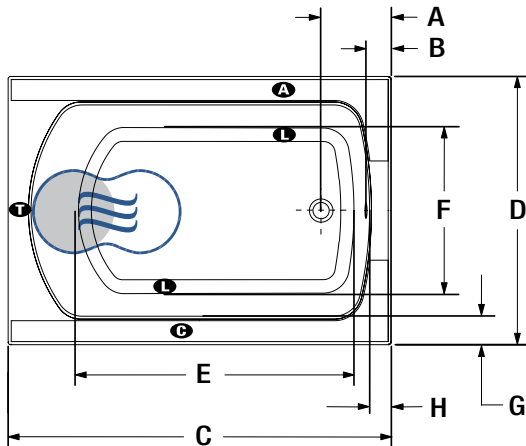

LETTER	DESCRIPTION	MEASURE
A	Outside edge to center waste	11"
B	Outside edge to overflow	4"
C	Total length	60"
D	Total width	42"
E	Bathing well length	43 5/8"
F	Bathing well width	26 1/4"
G	Deck width	4 1/4"
H	Deck width at waste end	3 1/2"
I	Height from bottom of tub to top deck	20 1/2"
J	Height from bottom of tub to bottom of lip	19"
K	Height from waste to center of overflow	17"
L	Maximum water level	14 3/8"
M	Slope of backrest	24°

- Indicates turbine position (TMU)
- Indicates heated backrest (TMU)
- Indicates WarmTouchShell position (TMSU)
- Indicates LED light position
- Indicates control position when factory-installed
- Indicates AromaCloud position

When tiling flange is added, the AromaCloud will automatically be installed on the opposite side of the flange.

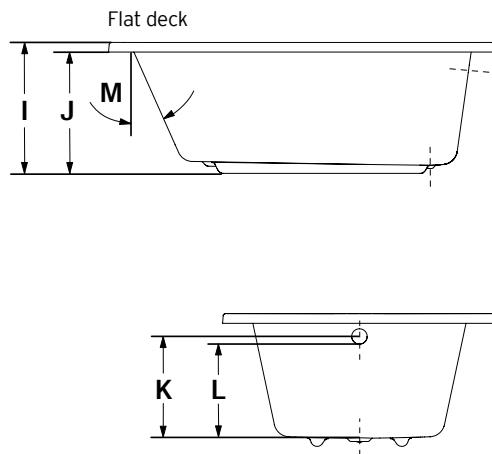

TECHNICAL SPECIFICATIONS

Hot water supply required	Should be 70% of water capacity of tub or greater.
Turbine	Access to the pump must be at least 18" X 22". Standard connection is 20 A, 120 V, 60 hz, dedicated line with a Ground-Fault Circuit Interrupter (GFCI). For any additional option, a second line is needed 15 A, 120 V, 60 hz, dedicated line with a GFCI. Air vent necessary: 2" X 4" minimum

Our products must be installed by certified professionals only and according to our Owner's Manual as well as federal, provincial/state and local building codes and regulations (www.bainultra.com/documentation/documentation).

Approx. shipping weight	126 lbs
Turbine power	600 W
Air heater	700 W

WARRANTY

Controls-LED-Geysair*	5 years
Bath & turbine*	20 years

*Some restrictions apply | www.bainultra.com/warranty



The specifications shown indicate the outer edge dimension and the inside bathing capacity dimension measured at air jets' height. The manufacturer accepts a 1/4" [0,64 cm] variance. There are variations on each product and specifications are subject to change as we improve upon our product as required. The dimensions needed for site preparation and structure building will differ. BainUltra® assumes no responsibility for preparatory work done prior to the product being on site.