

PRODUCT SHEET
THERMAL CR2K
 60" X 60" X 21"



THERMOMASSEUR® BATH	\$
THERMASENS® BATH	N/A
TUB	\$

THERMOMASSEUR (TMU)	
Jets	42
1 heated backrest	included
1 heated headrest	included
MiaPlus® Control	included
Geysair®	included
AromaCloud®	N/A
Chromatherapy - 3 LED	\$
2 nd heated backrest (advanced technology)	\$

TUB	
Chromatherapy - 3 LED	\$
WarmTouchShell®	\$
DOT control	included with therapy
2 nd WarmTouchShell®	\$

FEATURES			
Installation		Drop-in or Corner	
No. of bathers		Armrests	4
US gallons	61	Grab bars	2
Imp. gallons	51		

OPTIONAL UPCHARGE APPLICABLE

COLOR

Standard	
	White
	Biscuit
Optional	\$
	Black
	Sandbar
	Gray

CONTROL (TMU ONLY)

MiaMulti®	\$
-----------	----

SKIRT **SJ-3 CR2K**

Skirt	\$
Optional color	\$

CLEAR ACRYLIC GRAB BARS

With Chrome, Brass or Brushed nickel inserts	\$
--	----

WASTE & OVERFLOW **16" X 35"**

Chrome	\$
White, Biscuit	\$
Brass	\$
Brushed nickel, Polished nickel & Oil-rubbed bronze	\$

TILE FLANGE

Ordered with bath, uninstalled	\$
Factory-installed	\$

DON'T FORGET THAT ORDERING A TILE FLANGE FOR THIS BATH IS POSSIBLE.

1 800 463.2187 info@bainultra.com From 8 a.m. to 8 p.m. Monday to Thursday (EST)
 From 8 a.m. to 5 p.m. on Friday (EST)

THERMAL CR2K 60" X 60" X 21"

ACCESSORIES (OPTIONAL)

CUTTING TEMPLATE

90000021

OTHER

Optional tile flange.

TOTAL PRICE

\$

DROP-IN/CORNER INSTALLATION

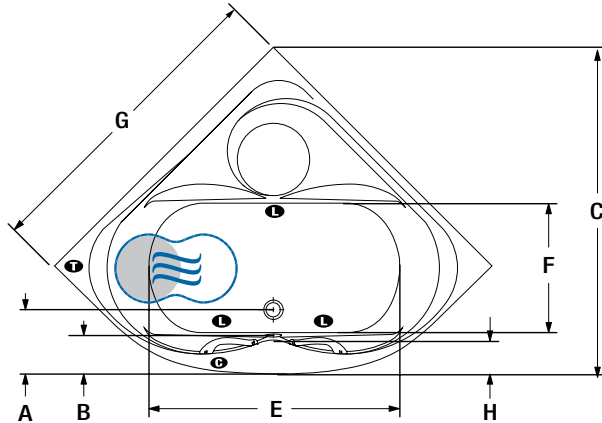

LETTER	DESCRIPTION	MEASURE
A	Outside edge to center drain	12 3/4"
B	Outside edge to overflow	7 3/8"
C	Total length	63 1/4"
D	Total width	84 1/8"
E	Bathing well length	46 1/2"
F	Bathing well width	25"
G	Sidewall length	59 3/4"
H	Deck width (widest point)	7 1/4"
I	Total height to raised headrest	23"
J	Height from bottom of tub to top deck	21 1/4"
K	Height from bottom of tub to bottom of lip	19 3/4"
L	Height from drain to center of overflow	16 7/8"
M	Maximum water level	15"
N	Slope of backrest	21°
O	Slope of backrest	28°

- T Indicates turbine position (TMU)
- L Indicates LED light position
- W Indicates WarmTouchShell position (TMSU)
- H Indicates heated backrest (TMU)
- G Indicates control position when factory-installed (Mia or Dot)

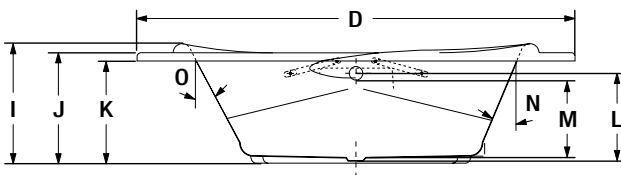

TECHNICAL SPECIFICATIONS

Hot water supply required	Should be 70% of water capacity of tub or greater.
Turbine	Access to the pump must be at least 18" X 22". Standard connection is 20 A, 120 V, 60 hz, dedicated line with a Ground-Fault Circuit Interrupter (GFCI). For any additional option, a second line is needed 15 A, 120 V, 60 hz, dedicated line with a GFCI. Air vent necessary: 2" X 4" minimum

Our products must be installed by certified professionals only and according to our Owner's Manual as well as federal, provincial/state and local building codes and regulations (www.bainultra.com/documentation/documentation).

Approx. shipping weight	192 lbs
Turbine power	600 W
Air heater	700 W

WARRANTY

Controls-LED-Geysair*	5 years
Bath & turbine*	20 years

*Some restrictions apply | www.bainultra.com/warranty



The specifications shown indicate the outer edge dimension and the inside bathing capacity dimension measured at air jets' height. The manufacturer accepts a 1/4" [0,64 cm] variance. There are variations on each product and specifications are subject to change as we improve upon our product as required. The dimensions needed for site preparation and structure building will differ. BainUltra® assumes no responsibility for preparatory work done prior to the product being on site.