



PRODUCT SHEET
OVAL PLUS
 66" X 38" X 19"







THERMOMASSEUR® BATH	\$
THERMASENS® BATH	\$
TUB	\$

THERMOMASSEUR (TMU)	
Jets	42
1 heated backrest	included
1 heated headrest	included
MiaPlus® Control	included
Geysair®	included
AromaCloud®	\$
Chromatherapy - 2 LED	\$

THERMASENS (TMSU)		TUB
AromaCloud®	included	\$
Chromatherapy - 2 LED	included	\$
WarmTouchShell®	included	\$
DOT control	included	included with therapy

FEATURES			
Installation			Drop-in
No. of bathers	2	Armrests	2
US gallons	44	Grab bars	2
Imp. gallons	36		

OPTIONAL UPCHARGE APPLICABLE	
COLOR	
Standard	
 White	 Biscuit
Optional	
 Black	 Sandbar
 Gray	\$
CONTROL (TMU ONLY)	
MiaMulti®	\$
CLEAR ACRYLIC GRAB BARS	
With Chrome, Brass or Brushed nickel inserts	\$
WASTE & OVERFLOW 16" X 35"	
Chrome	\$
White, Biscuit	\$
Brass	\$
Brushed nickel, Polished nickel & Oil-rubbed bronze	\$

1 800 463.2187  From 8 a.m. to 8 p.m. Monday to Thursday (EST)
 info@bainultra.com  From 8 a.m. to 5 p.m. on Friday (EST)

OVAL PLUS 66" X 38" X 19"

ACCESSORIES (OPTIONAL)

CUTTING TEMPLATE

90000010





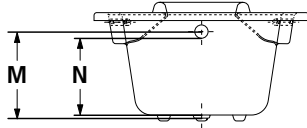
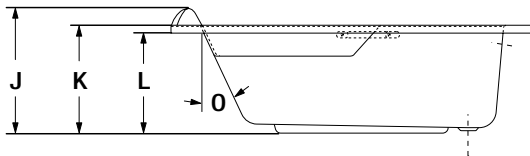
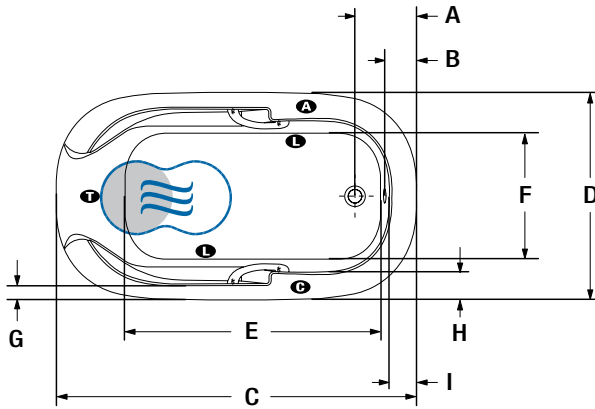

TOTAL PRICE

\$

DROP-IN INSTALLATION



LETTER	DESCRIPTION	MEASURE
A	Outside edge to center drain	11 1/2"
B	Outside edge to overflow	5 1/4"
C	Total length	65 3/4"
D	Total width	37 7/8"
E	Bathing well length	46 1/2"
F	Bathing well width	23"
G	Deck width (narrowest point)	3"
H	Deck width (widest point)	5 1/8"
I	Deck width	5 1/8"
J	Total height to headrest	22 3/8"
K	Height from bottom of tub to top deck	19 1/4"
L	Height from bottom of tub to bottom of lip	17 7/8"
M	Height from drain to center of overflow	14 3/8"
N	Maximum water level	12 7/8"
O	Slope of backrest	28°

-  Indicates turbine position (TMU)
-  Indicates heated backrest (TMU)
-  Indicates WarmTouchShell position (TMS)
-  Indicates LED light position
-  Indicates control position when factory-installed
-  Indicates AromaCloud position

TECHNICAL SPECIFICATIONS

Hot water supply required Should be 70% of water capacity of tub or greater.

Turbine Access to the pump must be at least 18" X 22". **Standard connection is 20 A, 120 V, 60 hz,** dedicated line with a Ground-Fault Circuit Interrupter (GFCI). **For any additional option, a second line is needed 15 A, 120 V, 60 hz,** dedicated line with a GFCI. Air vent necessary: 2" X 4" minimum

Our products must be installed by certified professionals only and according to our Owner's Manual as well as federal, provincial/state and local building codes and regulations (www.bainultra.com/documentation/documentation).

Approx. shipping weight 122 lbs

Turbine power 600 W

Air heater 700 W

WARRANTY

Controls-LED-Geysair* 5 years

Bath & turbine* 20 years

*Some restrictions apply | www.bainultra.com/warranty



The specifications shown indicate the outer edge dimension and the inside bathing capacity dimension measured at air jets' height. The manufacturer accepts a 1/4" [0,64 cm] variance. There are variations on each product and specifications are subject to change as we improve upon our product as required. The dimensions needed for site preparation and structure building will differ. BainUltra® assumes no responsibility for preparatory work done prior to the product being on site.