



PRODUCT SHEET
ELEGANCIA 6636
 66" X 36" X 21"



THERMOMASSEUR® BATH	\$
TUB	\$

THERMOMASSEUR (TMU)	
Jets	36
1 heated backrest	included
MiaPlus® Control	included
Geysair®	included
AromaCloud®	\$
Illuzio Chromatherapy NEW	\$
2 nd heated backrest (advanced technology)	\$

TUB (soaker)	
AromaCloud®	\$
Illuzio Chromatherapy NEW	\$
WarmTouchShell®	\$
DOT control	included with therapy
2 nd WarmTouchShell®	\$

FEATURES			
Installation types	Drop-in & Alcove (3 walls) for C12 only		
No. of bathers		Armrests	4
US gallons	46	Grab bars (color match)	2
Imp. gallons	38		

COLOR	
Standard	
White	Biscuit

OPTIONAL UPCHARGE APPLICABLE

COLOR	
Optional	\$
Gray	

CONTROL (TMU ONLY)		
MiaMulti®	\$	
SKIRT (WITH C12)	MULTIFIT	SJ-1
Skirt	\$	\$
Optional color	\$	\$

GRAB BARS	G11 METALLIC	CLEAR ACRYLIC**
Chrome & Brass	\$	\$
Brushed & polished nickel	\$	\$

WASTE & OVERFLOW	D14* (ELEGANCIA)	D13 (BALNEO®)
Chrome	\$	\$
White, Biscuit	\$	N/A
Brass	\$	\$
Brushed nickel & Polished nickel	\$	\$
Unplated & Oil-rubbed bronze	N/A	\$

TILE FLANGE (FOR C12 CONTOUR ONLY) (specify front or back)	
Ordered with bath, uninstalled	\$
Factory-installed	\$

** With Chrome, Brass or Brushed nickel inserts.

1 800 463.2187
 info@bainultra.com

From 8 a.m. to 8 p.m. Monday to Thursday (EST)
 From 8 a.m. to 5 p.m. on Friday (EST)

ELEGANCIA 6636 66" X 36" X 21"

ACCESSORIES (OPTIONAL)

CUTTING TEMPLATE

90000044 (C11, C13 & C14)

OTHER

- Optional tile flange for C12 contour (specify front or back).

TOTAL PRICE

\$

DROP-IN/ALCOVE INSTALLATION

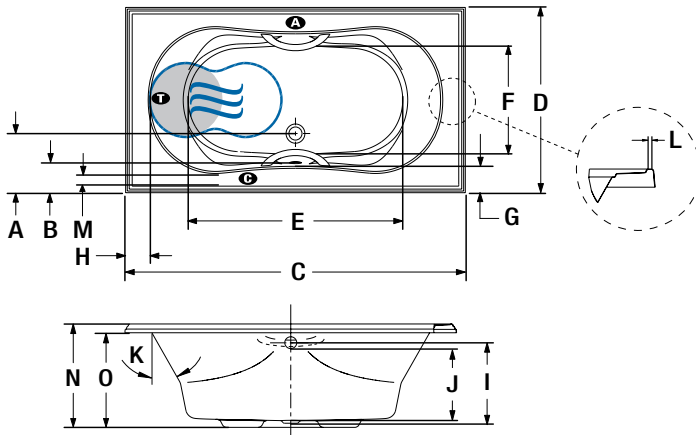

LETTER	DESCRIPTION	MEASURE
A	Outside edge to center waste	11 1/2"
B	Outside edge to overflow	5 1/2"
C	Total length	66"
D	Total width	36"
E	Bathing well length	42"
F	Bathing well width	21 3/8"
G	Deck width at backrest end (widest point)	5 1/4"
H	Deck width at backrest end	4 3/4"
I	Height from waste to center of overflow	16"
J	Maximum water level	14 3/8"
K	Slope of backrest	30°
L	Flat contour width (narrowest point) C12 ONLY	0 3/8"

- A** AromaCloud position
- C** Control position when factory-installed (Mia or Dot)
- T** Turbine position (TMU)
- Heated backrest (TMU)
- ☄ WarmTouchShell position

When tiling flange is added, the AromaCloud will automatically be installed on the opposite side of the flange.

CHOOSE YOUR CONTOUR

LETTER	DESCRIPTION	C10	C11	C12	C13	C14
M	Deck width (narrowest point)	3 1/4"	3 1/2"	3 5/8"	3 5/8"	3 1/4"
N	Height from bottom of tub to top deck	20 3/4"	20 5/8"	21"	20 5/8"	20 3/4"
O	Height from bottom of tub to bottom of lip	18 1/4"	17 5/8"	19"	18 5/8"	18 1/4"

💡 DON'T FORGET TO SELECT A CONTOUR AMONG THE 5 AVAILABLE TO CHOOSE FROM.
 * PIPING IS NOT INCLUDED FOR THIS MODEL (D14).
 ** SPECIFY INSERT FINISH.



TECHNICAL SPECIFICATIONS

Hot water supply required	Should be 70% of water capacity of tub or greater.
Turbine	Access to the pump must be at least 18" X 22". Standard connection is 20 A. 120 V, 60 hz , dedicated line with a Ground-Fault Circuit Interrupter (GFCI). For any additional option, a second line is needed 15 A. 120 V, 60 hz , dedicated line with a GFCI. Air vent necessary: 2" X 4" minimum

Our products must be installed by certified professionals only and according to our Owner's Manual as well as federal, provincial/state and local building codes and regulations (www.bainultra.com/documentation/documentation).

Approx. shipping weight	135 lbs
Turbine power	550 W
Air heater	600 W

WARRANTY

Controls-LED-Geysair*	5 years
Bath & turbine*	20 years

*Some restrictions apply | www.bainultra.com/warranty



The specifications shown indicate the outer edge dimension and the inside bathing capacity dimension measured at air jets' height. The manufacturer accepts a 1/4" [0,64 cm] variance. There are variations on each product and specifications are subject to change as we improve upon our product as required. The dimensions needed for site preparation and structure building will differ. BainUltra® assumes no responsibility for preparatory work done prior to the product being on site.