



PRODUCT SHEET

ESTHESIA 6436

64" X 36" X 25"



FREESTANDING

THERMOMASSEUR® BATH	\$
TUB	\$

THERMOMASSEUR (TMU)	
Jets	38
1 heated backrest	included
MiaPlus® Control	included
Geysair®	included
AromaCloud®	\$
Illuzio Chromatherapy NEW	\$
2 nd heated backrest (advanced technology)	\$

TUB (soaker)	
AromaCloud®	\$
Illuzio Chromatherapy NEW	\$
WarmTouchShell®	\$
2 nd WarmTouchShell®	\$
DOT control	included with therapy

FEATURES			
Installation type			Freestanding
No. of bathers	2	Integrated waste & overflow	inst. & incl.
US gallons	59		
Imp. gallons	49		
INTEGRATED WASTE & OVERFLOW			
Chrome, White			
Brass, Brushed Nickel, Polished Nickel			

FEATURES (INCLUDED)

COLOR

Standard



White

OPTIONAL UPCHARGE APPLICABLE

FINISH

UltraVelour Matte Finish (White Only)	\$
---------------------------------------	----

CONTROL (TMU ONLY)

MiaMulti Control	\$
------------------	----

ISLAND TUB DRAIN™*

Island Tub Drain™	\$
-------------------	----



DON'T FORGET THAT THIS MODEL IS AVAILABLE IN WHITE ONLY.
DON'T FORGET TO SPECIFY THE FINISH OF THE INTEGRATED WASTE & OVERFLOW.
 * AN ISLAND TUB DRAIN IS REQUIRED WHEN THERE IS NO ACCESS UNDER THE BATH.

1 800 463.2187 info@bainultra.com

From 8 a.m. to 8 p.m. Monday to Thursday (EST)
 From 8 a.m. to 5 p.m. on Friday (EST)

BainUltra®

The quest for your wellness®

www.bainultra.com

ESTHESIA 6436 64" X 36" X 25"

ACCESSORIES (OPTIONAL)

CUTTING TEMPLATE

900000066

OTHERS

- Faucet must be freestanding or wall-mounted.
- The turbine must be remotely installed.

TOTAL PRICE

\$

FREESTANDING INSTALLATION

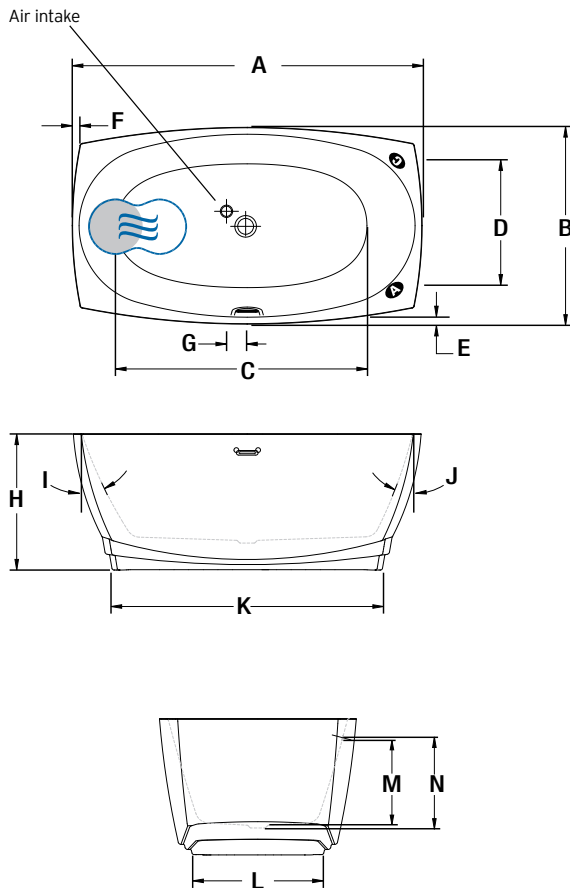

LETTER	DESCRIPTION	MEASURE
A	Total length	64"
B	Total width	36"
C	Bathing well length	47 3/8"
D	Bathing well width	23"
E	Deck width	15/8"
F	Deck width at headrest	15/8"
G	Center waste to air intake	3 1/2"
H	Total height	25"
I	Slope of backrest	26°
J	Slope of backrest	21°
K	Base length	49 5/8"
L	Base width	23 7/8"
M	Height from drain to center of overflow	16 5/8"
N	Maximum water level	15 7/8"

A AromaCloud position

● Heated backrest (TMU)

G Control position when factory-installed

☞ WarmTouchShell position

TECHNICAL SPECIFICATIONS

Hot water supply required	Should be 70% of water capacity of tub or greater.
Turbine	Access to the pump must be at least 18" X 22". Standard connection is 20 A, 120 V, 60 hz , dedicated line with a Ground-Fault Circuit Interrupter (GFCI). For any additional option, a second line is needed 15 A, 120 V, 60 hz , dedicated line with a GFCI. Air vent necessary: 2" X 4" minimum

Our products must be installed by certified professionals only and according to our Owner's Manual as well as federal, provincial/state and local building codes and regulations (www.bainultra.com/documentation/documentation).

Approx. shipping weight	240 lbs
Turbine power	550 W
Air heater	600 W

WARRANTY

Controls-LED-Geysair*	5 years
Bath & turbine*	20 years

*Some restrictions apply | www.bainultra.com/warranty



The specifications shown indicate the outer edge dimension and the inside bathing capacity dimension measured at air jets' height. The manufacturer accepts a 1/4" [0.64 cm] variance. There are variations on each product and specifications are subject to change as we improve upon our product as required. The dimensions needed for site preparation and structure building will differ. BainUltra® assumes no responsibility for preparatory work done prior to the product being on site.