



PRODUCT SHEET

NOKORI 6935

69" X 35" X 24"



FREESTANDING

THERMOMASSEUR® BATH	\$
TUB	\$

THERMOMASSEUR (TMU)

Jets	44
1 heated backrest	included
MiaPlus® Control* (not installed)	included
Geysair®	included
AromaCloud®	N/A
Illuzio Chromatherapy NEW	\$
2 nd heated backrest (advanced technology)	\$

TUB (soaker)

AromaCloud®	N/A
Illuzio Chromatherapy NEW	\$
WarmTouchShell®	\$
DOT control (not installed)	included with therapy
2 nd WarmTouchShell®	\$

FEATURES

Installation type	Freestanding		
No. of bathers	2	Integrated waste & overflow	inst. & incl.
US gallons	78		
Imp. gallons	65		

WASTE & OVERFLOW

Chrome, White
Brass, Brushed Nickel, Polished Nickel

FEATURES

COLOR

Standard



White

OPTIONAL UPCHARGE APPLICABLE

FINISH

UltraVelour Matte Finish (White Only)	\$
---------------------------------------	----

CONTROL* (TMU ONLY)

MiaMulti®	\$
-----------	----

AIR INTAKE** & ISLAND TUB DRAIN***

Air intake & Island Tub Drain™	\$
Island Tub Drain™	\$
Air intake	\$
Air intake installation	\$

NOKORI SPECIAL TILE FLANGE (SPECIFY POSITION)

Ordered with bath, uninstalled	\$
Factory installed	\$



DON'T FORGET THAT THIS TUB IS AVAILABLE IN **WHITE ONLY**.

* CONTROL AND FAUCET CANNOT BE INSTALLED ON THE DECK OF THE BATH.

** AIR INTAKE AND ACCESS TO ELECTRONICS ARE REQUIRED.

IF TURBINE IS INSTALLED UNDER THE BATH, PLEASE FOLLOW THE **TURBINE INSTALLATION UNDER THE BATH SECTION** IN THE **NOKORI INSTALLATION INSTRUCTIONS**.

*** AN ISLAND TUB DRAIN™ IS REQUIRED WHEN THERE IS NO ACCESS UNDER THE BATH.

1 800 463.2187
info@bainultra.com

From 8 a.m. to 8 p.m. Monday to Thursday (EST)
From 8 a.m. to 5 p.m. on Friday (EST)

BainUltra®

The quest for your wellness™

www.bainultra.com

NOKORI 6935 69" X 35" X 24"

ACCESSORIES (OPTIONAL)

OTHERS

- Faucet must be freestanding or wall-mounted.
- Controls cannot be installed on the bath.
- The turbine should be remotely installed.
- The turbine can also be installed under the bath. Please refer to the Nokori Installation Instructions - Turbine Installation under the bath.

TOTAL PRICE

\$

FREESTANDING INSTALLATION

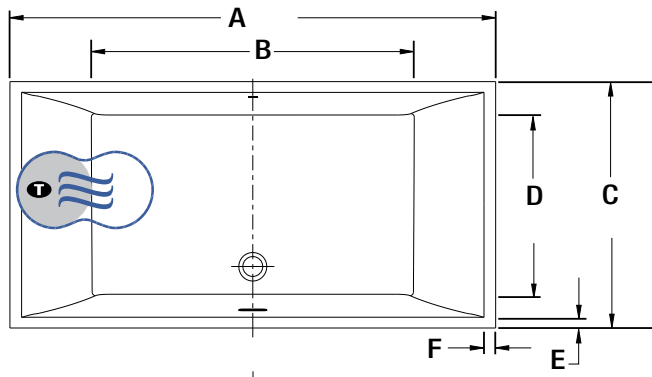

LETTER	DESCRIPTION	MEASURE
A	Total length	69"
B	Bathing well length	45"
C	Total width	35"
D	Bathing well width	26 1/4"
E	Deck width	2 "
F	Deck width at backrest	1 5/8"
G	Slope of backrest	24°
H	Outside edge to center of waste	8 3/4"
I	Height from waste to top of deck	21 "
J	Maximum water level	16 3/4"
K	Total height	24"

I Turbine position (TMU)

● Heated backrest (TMU)
 WarmTouchShell position

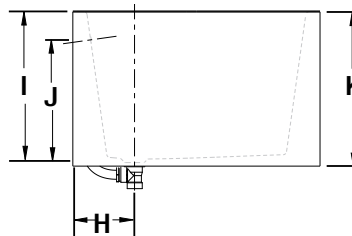
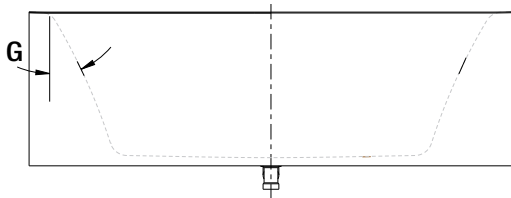

TECHNICAL SPECIFICATIONS

Hot water supply required	Should be 70% of water capacity of tub or greater.
Turbine	Access to the pump must be at least 18" X 22". Standard connection is 20 A, 120 V, 60 hz , dedicated line with a Ground-Fault Circuit Interrupter (GFCI). For any additional option, a second line is needed 15 A, 120 V, 60 hz , dedicated line with a GFCI. Air vent necessary: 8 sq. in. minimum

Our products must be installed by certified professionals only and according to our Owner's Manual as well as federal, provincial/state and local building codes and regulations (www.bainultra.com/documentation/documentation).

The specifications shown indicate the outer edge dimension and the inside bathing capacity dimension measured at air jets' height. The manufacturer accepts a 1/4" [0,64 cm] variance. There are variations on each product and specifications are subject to change as we improve upon our product as required. The dimensions needed for site preparation and structure building will differ. BainUltra® assumes no responsibility for preparatory work done prior to the product being on site.

Approx. shipping weight	300 lbs
Turbine power	550 W
Air heater	600 W

WARRANTY

Controls-LED-Geysair*	5 years
Bath & turbine*	20 years

*Some restrictions apply | www.bainultra.com/warranty

