



PRODUCT SHEET
THERMAL 50
 60" X 32" X 20"







THERMOMASSEUR® BATH	\$
THERMASENS® BATH	\$
TUB	\$

THERMOMASSEUR (TMU)	
Jets	36
1 heated backrest	included
1 heated headrest	included
MiaPlus® Control	included
Geysair®	included
AromaCloud®	\$
Chromatherapy - 2 LED	\$

THERMASENS (TMSU)		TUB
AromaCloud®	included	\$
Chromatherapy - 2 LED	included	\$
WarmTouchShell®	included	\$
DOT control	included	included with therapy

FEATURES			
Installation			Drop-in
No. of bathers	↓	Imp. gallons	34
US gallons	40	Armrests	2

OPTIONAL UPCHARGE APPLICABLE

COLOR	
Standard	
 White	 Biscuit
Optional	
 Black	 Sandbar
 Gray	\$
CONTROL (TMU ONLY)	
MiaMulti®	\$
DRAIN & OVERFLOW 16" X 35"	
Chrome	\$
White, Biscuit	\$
Brass	\$
Brushed nickel, Polished nickel & Oil-rubbed bronze	\$

 HAVE YOU THOUGHT ABOUT SUGGESTING THE PURCHASE OF BAINULTRA® ESSENTIAL OILS SO THAT YOUR CUSTOMER MAY ENJOY AROMATHERAPY?

1 800 463.2187  info@bainultra.com | From 8 a.m. to 8 p.m. Monday to Thursday (EST)
 From 8 a.m. to 5 p.m. on Friday (EST)

THERMAL 50 60" X 32" X 20"

ACCESSORIES (OPTIONAL)

OTHER

Optional tile flange (specify right or left).





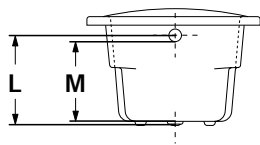
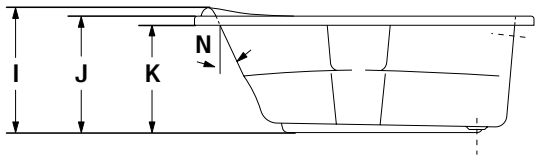
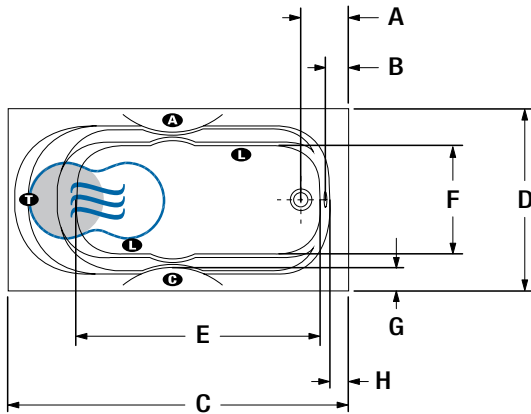

TOTAL PRICE

\$

DROP-IN INSTALLATION



LETTER	DESCRIPTION	MEASURE
A	Outside edge to center drain	9 1/8"
B	Outside edge to overflow	3 1/4"
C	Total length	59 3/4"
D	Total width	31 5/8"
E	Bathing well length	43 3/8"
F	Bathing well width	19"
G	Deck width (widest point)	4 1/4"
H	Deck width at drain end	3"
I	Total height to headrest	21 1/2"
J	Height from bottom of tub to top deck	20 1/8"
K	Height from bottom of tub to bottom of lip	18 5/8"
L	Height from drain to center of overflow	16 1/8"
M	Maximum water level	14 3/8"
N	Slope of backrest	24°

-  Indicates turbine position (TMU)
-  Indicates LED light position
-  Indicates heated backrest (TMU)
-  Indicates control position when factory-installed
-  Indicates WarmTouchShell position (TMSU)
-  Indicates AromaCloud position

When tiling flange is added, the AromaCloud will automatically be installed on the opposite side of the flange.

TECHNICAL SPECIFICATIONS

Hot water supply required Should be 70% of water capacity of tub or greater.

Turbine Access to the pump must be at least 18" X 22". **Standard connection is 20 A, 120 V, 60 hz,** dedicated line with a Ground-Fault Circuit Interrupter (GFCI). **For any additional option, a second line is needed 15 A, 120 V, 60 hz,** dedicated line with a GFCI. Air vent necessary: 2" X 4" minimum

Our products must be installed by certified professionals only and according to our Owner's Manual as well as federal, provincial/state and local building codes and regulations (www.bainultra.com/documentation/documentation).

Approx. shipping weight 135 lbs

Turbine power 600 W

Air heater 700 W

WARRANTY

Controls-LED-Geysair* 5 years

Bath & turbine* 20 years

*Some restrictions apply | www.bainultra.com/warranty



The specifications shown indicate the outer edge dimension and the inside bathing capacity dimension measured at air jets' height. The manufacturer accepts a 1/4" [0,64 cm] variance. There are variations on each product and specifications are subject to change as we improve upon our product as required. The dimensions needed for site preparation and structure building will differ. BainUltra® assumes no responsibility for preparatory work done prior to the product being on site.